

SIEMENS

SINUMERIK 802D sl pro

Turning

Control system overview for
machine tools' sales people

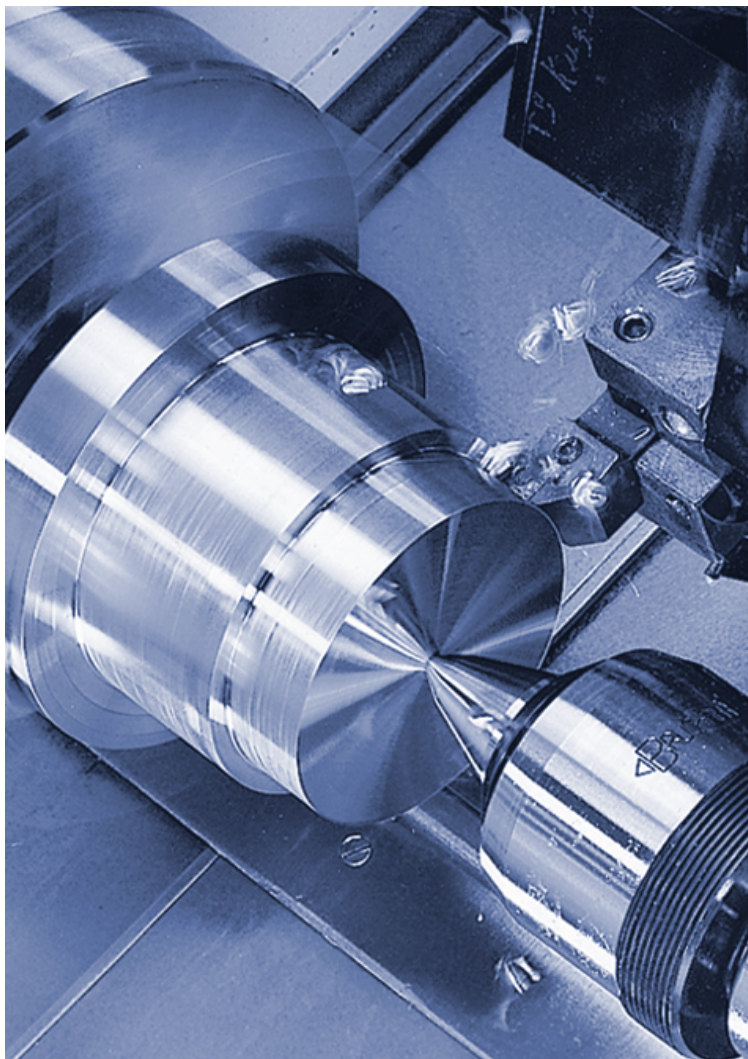



03/2008

Foreword	
Introduction	1
System overview	2
Setup functions	3
Program management and user memory	4
Programming	5
Simulation	6
Automatic mode	7
Velocity control	8
C axis processing	9
Multilingual operator interface	10
Maintenance and diagnostics	11
PC software	12
Ordering data	13
Summary of unique selling points	14

Safety Guidelines

This manual contains notices you have to observe in order to ensure your personal safety, as well as to prevent damage to property. The notices referring to your personal safety are highlighted in the manual by a safety alert symbol, notices referring only to property damage have no safety alert symbol. These notices shown below are graded according to the degree of danger.

 DANGER
indicates that death or severe personal injury will result if proper precautions are not taken.
 WARNING
indicates that death or severe personal injury may result if proper precautions are not taken.
 CAUTION
with a safety alert symbol, indicates that minor personal injury can result if proper precautions are not taken.
CAUTION
without a safety alert symbol, indicates that property damage can result if proper precautions are not taken.
NOTICE
indicates that an unintended result or situation can occur if the corresponding information is not taken into account.

If more than one degree of danger is present, the warning notice representing the highest degree of danger will be used. A notice warning of injury to persons with a safety alert symbol may also include a warning relating to property damage.

Qualified Personnel

The device/system may only be set up and used in conjunction with this documentation. Commissioning and operation of a device/system may only be performed by **qualified personnel**. Within the context of the safety notes in this documentation qualified persons are defined as persons who are authorized to commission, ground and label devices, systems and circuits in accordance with established safety practices and standards.

Prescribed Usage

Note the following:

 WARNING
This device may only be used for the applications described in the catalog or the technical description and only in connection with devices or components from other manufacturers which have been approved or recommended by Siemens. Correct, reliable operation of the product requires proper transport, storage, positioning and assembly as well as careful operation and maintenance.

Trademarks

All names identified by ® are registered trademarks of the Siemens AG. The remaining trademarks in this publication may be trademarks whose use by third parties for their own purposes could violate the rights of the owner.

Disclaimer of Liability

We have reviewed the contents of this publication to ensure consistency with the hardware and software described. Since variance cannot be precluded entirely, we cannot guarantee full consistency. However, the information in this publication is reviewed regularly and any necessary corrections are included in subsequent editions.

Foreword

Scope of validity

This document provides you with an overview of the range of functions included in the operator panel control **SINUMERIK 802D solution line pro** Version 1.4 for turning machines.

The document is oriented towards vendors and dealers of machine tools.

Organization of information

- Of the varied functional possibilities of this SINUMERIK product, we only designate those qualities which are of direct value to the machine's user.
- All functions contained in the machine's basic configuration will be identified as follows:
 - Basic configuration
- All functions not contained in the machine's basic configuration will be identified as follows:
 - Option: ...
- A summary of the unique selling points of the SINUMERIK 802D sl pro in comparison with competitors, may be found in the chapter "Summary of unique selling points".
- For information on marketing options through the machine manufacturer, please see the technical description of each machine.

Subject to change without prior notice

Contact person at machine manufacturer

Marketing & Sales

Phone:	+49 xxx xxx
Fax:	+49 xxx xxx
E-mail:	xxx@machinemanufacturer.com
Web:	http://www.machinemanufacturer.com

Service

Phone:	+49 xxx xxx
Fax:	+49 xxx xxx
E-mail:	xxx@machinemanufacturer.com
Web:	http://www.machinemanufacturer.com

Homepage:

<http://www.machinemanufacturer.com>

Contact person at Siemens

Sales & Marketing/Technical Consulting

Phone: +49 xxx xxx
Fax: +49 xxx xxx
Web: <http://www4.ad.siemens.de> (worldwide)

Service

Phone: +49 xxx xxx
Fax: +49 xxx xxx
Web: <http://www4.ad.siemens.de> (worldwide)

Homepage:

Visit the JobShop internet portal:
<http://www.siemens.com/jobshop>

Table of contents

	Foreword	3
1	Introduction.....	7
	1.1 Application.....	7
	1.2 Machine spectrum.....	7
2	System overview.....	9
	2.1 SINUMERIK 802D sl.....	9
	2.2 Operator panel	10
3	Setup functions.....	11
	3.1 Work offsets	11
	3.2 ToolMeasuring	12
	3.2.1 Measure tools manually in JOG.....	12
	3.2.2 Measure tools automatically in JOG	13
	3.3 Tool management	14
	3.3.1 Tool list.....	14
	3.3.2 Monitoring of tool life and quantity of workpieces	15
	3.4 Face turning in MDA mode	16
4	Program management and user memory	17
	4.1 Program Manager	17
	4.2 User memory and data management	18
	4.2.1 Buffered CNC user memory.....	18
	4.2.2 Compact Flash card.....	18
	4.2.3 Serial data transfer.....	19
	4.2.4 Ethernet networking	19
5	Programming	21
	5.1 DIN/ISO language.....	21
	5.2 DIN/ISO editor.....	22
	5.3 Machining Cycles.....	23
	5.4 On-board user manual	25
	5.5 On-board pocket calculator.....	26
	5.6 Free Contour Programming / Contour Calculator	27
6	Simulation.....	29
7	Automatic mode.....	31
	7.1 Program control.....	31
	7.2 Block search.....	32

8	Velocity control	33
8.1	Jerk limitation	33
8.2	Dynamic feedforward control	34
9	C axis processing	35
9.1	Front surface machining.....	35
9.2	Peripheral surface machining.....	36
10	Multilingual operator interface.....	37
11	Maintenance and diagnostics	39
11.1	Maintenance-free operation	39
11.2	Diagnostics.....	40
11.3	Remote diagnostics.....	41
12	PC software	43
12.1	CAD reader for PC	43
12.2	SINUMERIK 802D on PC - SinuTrain.....	44
12.3	SINUMERIK 802D self-learning CD.....	44
13	Ordering data.....	45
14	Summary of unique selling points	47
	Index.....	49

Introduction

1.1 Application

The SINUMERIK 802D sl pro is a customized operator panel controller for standard CNC turning machines..

The SINUMERIK 802D sl pro allows you to easily operate machine tools by providing graphical support for all operator control actions.

The functions in JOG (manual) mode enable you to quickly set the machine up for machining, in accordance with your requirements. More specifically, this consists of calculating the workpiece position in the machine, as well as maintaining and measuring the tools in use.

For programming purposes, the SINUMERIK 802D sl pro provides you with a DIN/ISO editor that is easy to operate and has a complete G-code in accordance with DIN66025 and ISO dialect. During programming, graphical support is provided for technology canned cycles and contours.

The SINUMERIK 802D sl pro is an efficient complete system, covering all required fields of application without additional setup and training costs:

- Easy-to-use interface for all machine functions
- Graphical interfaces for technology canned cycles and contour editor
- DIN/ISO programming on the machine
- DIN/ISO programming offline via CAD/CAM system
- Automatic tool measuring during setup

1.2 Machine spectrum

The SINUMERIK 802D sl pro is particularly recommended for the following machine types:

1. Single-slide turning machines with X and Z axes
 - Turning
 - Centric drilling on the end face
2. Like 1.) with rotating tools (C axis mode)

System overview

2.1 SINUMERIK 802D sl

The SINUMERIK 802D sl operator panel controller is the ideal package for use with standardized turning and milling machines. Used in conjunction with the new, compact and reliable SINAMICS S120 drive system, the SINUMERIK 802D sl is a complete package for machine tool applications. These range from low-volume production to medium-volume production to production of more advanced workpieces with any type of hole machining and milling on end face and outer surface.

- Digital drive technology via DRIVE-CLiQ
- Up to 4 interpolating axes and one spindle
- Identical hardware and software for turning and milling
- Powerful PLC based on SIMATIC S7-200 with "ladder logic" programming
- Large, easy-to-read color display

 See catalog NC 61 for additional information

Highlights



- **Powerful and reliable machine package from Siemens**
- **Extremely dynamic drives and motors**
- **Matched, complete package**

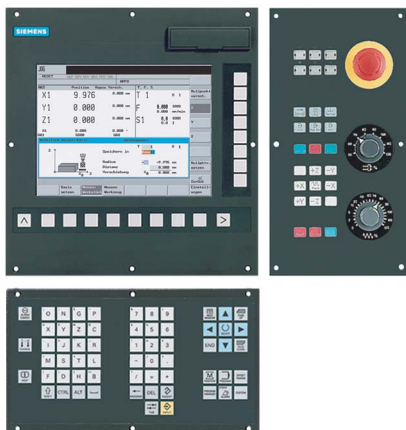

SINUMERIK 802D sl
with 10.4 inch TFT color display,
CNC keyboard and machine control panel



Modular
SINAMICS
Drive System



1PH7 spindle motor,
1FK7 servo motors

2.2 Operator panel

The operator panel front consists of an operator panel with a 10.4 inch color TFT display, 8 + 2 horizontal and 8 vertical softkeys, and a CNC keyboard (horizontal or vertical options available). This facilitates clear and user-friendly operation of the machine functions. We also offer the coordinated machine control panel MCP 802D sl with feed and spindle override.



Highlights



- All relevant functions at a glance, thanks to horizontal and vertical softkeys
- Brilliant color display, balanced and high-quality design of operator components
- Easy data handling thanks to the easily accessible Compact Flash card slot on the front

Setup functions

3.1 Work offsets

Basic configuration

Within the SINUMERIK 802D sl pro, the following adjustable work offsets are available:

- A permanently effective basic offset (G500)
- Other work offsets (G54-G59)

Graphical interface support is provided for the purpose of adjusting workpiece zeros. This means that you can switch directly between the Measure workpiece screens and Work offset list.

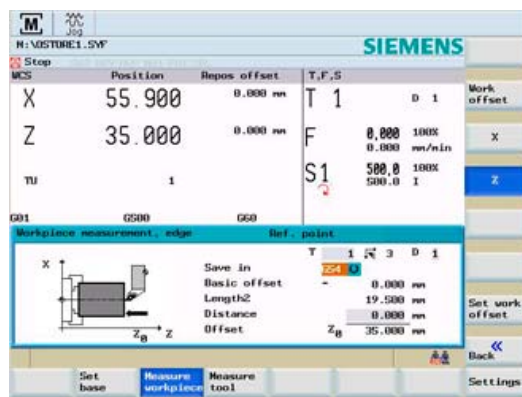

Work offset		MCS X1		MCS Z1		SP1	
MCS	X	Z	C	X	Z	C	Further axes
X	55.900 mm			36.925 mm			
Z	35.000 mm			54.500 mm			Measure workpiece
C	96.219 mm			96.219 mm			
	X	Z	C	X	Z	C	
Base	0.000	0.000	0.000	0.000	0.000	0.000	
G54	0.000	35.000	0.000	0.000	0.000	0.000	
G55	0.000	0.000	0.000	0.000	0.000	0.000	
G56	0.000	0.000	0.000	0.000	0.000	0.000	
G57	0.000	0.000	0.000	0.000	0.000	0.000	
G58	0.000	0.000	0.000	0.000	0.000	0.000	
G59	0.000	0.000	0.000	0.000	0.000	0.000	
Program	0.000	0.000	0.000	0.000	0.000	0.000	
Scale	1.000	1.000	1.000				
Mirror	0	0	0				
Total	0.000	0.000	0.000	0.000	0.000	0.000	

Highlights



- Easy setup of different workpieces using graphical guidance
- Clear overview of all work offsets

3.2 ToolMeasuring

3.2.1 Measure tools manually in JOG

Basic configuration

The tool compensation values can be directly determined during machine setup. To this end the SINUMERIK 802D sl pro offers graphical support for measuring tool length and diameter:

- Graphic support for measuring tools in the X- (length 1) and Z-direction (length 2)
 - Either enter the workpiece diameter in the \varnothing field or the workpiece length in the Z0 field.
 - After selecting the **SetLength1** or **SetLength2** softkey, the control system will determine the searched length 1 or length 2 according to the preselected axis.
 - The determined tool offset value will be saved and transferred into the tool list.
- Button for saving the position, to retract the tool from the workpiece, to stop the spindle, and to measure the workpiece prior to transferring the results

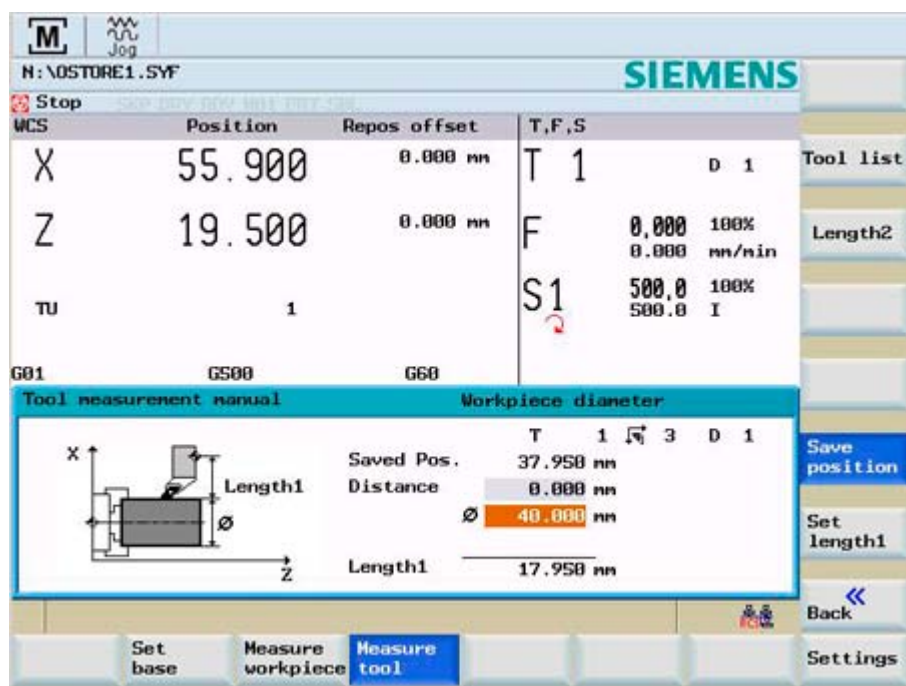

Highlight



- Save time during tool setup by seeing exactly what you are doing.

3.2.2 Measure tools automatically in JOG

Basic configuration

In JOG mode, the machine can automatically determine the tool compensation values for length 1 (X-direction) or length 2 (Z-direction). To this end the SINUMERIK 802D sl pro offers graphical support for automatic measuring and for calibrating the tool probe.

- To measure the tool length, simply move the tool near the probe.
- Click "Start". When the probe detects the tool, the controller automatically calculates the tool geometry.

MCS	Position	Repos offset	T,F,S
X	57.950	0.000 mm	T 1 D 1
Z	19.500	0.000 mm	F 0.000 100% 0.000 mm/min
TU	1		S1 0.0 100% 0.0 I

Tool measurement auto

Length1 17.958 mm

Buttons: Set base, Measure workpiece, Measure tool, Back, Settings

Highlight



- Speedy and precise tool measuring is standard
- Pre-installed graphic support for measuring with tool probe

3.3 Tool management

3.3.1 Tool list

Basic configuration

Type	T	D _Σ	Geometry			Wear		
			Length1	Length2	Radius	Length1	Length2	Radius
1	2		17.950	19.500	0.800	0.000	0.000	0.000
2	1		25.000	22.000	0.400	0.000	0.000	0.000
3	2		28.000	32.000	0.600	0.000	0.000	0.000
4	1		22.000	28.000	0.800	0.000	0.000	0.000
5	2		19.000	23.000	0.600	0.000	0.000	0.000
6	1		40.000	0.000	4.000	0.000	0.000	0.000
7	1		60.000	0.000	10.000	0.000	0.000	0.000
8	1		50.000	0.000	16.000	0.000	0.000	0.000
9	1		32.000	21.000	0.600	0.000	0.000	0.000
10	1		80.000	0.000	3.000	0.000	0.000	0.000
11	1		24.000	30.000	0.800	0.000	0.000	0.000
12	1		70.000	0.000	12.000	0.000	0.000	0.000

For managing tools, the SINUMERIK 802D sl pro provides you with an easy-to-use tool list, which displays all relevant tool data and wear.

- In the tool list, you can create and delete tools using softkeys.
- For each tool, you can store the following data:
 - Special icon for the individual tool type with direction of tool orientation (mill or drill)
 - Tools are displayed in the list with a number, e.g. T1.
 - Number of the compensation block for the tool cutting edge, e.g. D1
 - Tool offset data in the X/Z direction.
 - Radius for drilling tool and milling tools, or plate radius for turning tools
 - Values for geometry and wear in a single table
 - Display of the cutting position for turning tools
- Using individual password protection, you can specify the maximum permissible input values for tool wear to avoid collisions, for example. This can be done using display machine data MD 208, MD 209 and MD 374.

Highlight



- All tool data at a glance
- More safety in managing tool data

3.3.2 Monitoring of tool life and quantity of workpieces

Basic configuration

Type	T	D	Tool life [min]				Quantity			
			Setpt.	Prev.lt	Resid.	Activ	Setpt.	Prev.lt	Resid.	
1	2		100.000	10.000	99.658	<input checked="" type="checkbox"/>	50	5	50	<input checked="" type="checkbox"/>
2	1		0.000	0.000	0.000	<input type="checkbox"/>	0	0	0	<input type="checkbox"/>
3	2		0.000	0.000	0.000	<input type="checkbox"/>	0	0	0	<input type="checkbox"/>
4	1		0.000	0.000	0.000	<input type="checkbox"/>	0	0	0	<input type="checkbox"/>
5	2		0.000	0.000	0.000	<input type="checkbox"/>	0	0	0	<input type="checkbox"/>
6	1		0.000	0.000	0.000	<input type="checkbox"/>	0	0	0	<input type="checkbox"/>
7	1		0.000	0.000	0.000	<input type="checkbox"/>	0	0	0	<input type="checkbox"/>
8	1		0.000	0.000	0.000	<input type="checkbox"/>	0	0	0	<input type="checkbox"/>
9	1		0.000	0.000	0.000	<input type="checkbox"/>	0	0	0	<input type="checkbox"/>
10	1		0.000	0.000	0.000	<input type="checkbox"/>	0	0	0	<input type="checkbox"/>
11	1		0.000	0.000	0.000	<input type="checkbox"/>	0	0	0	<input type="checkbox"/>
12	1		0.000	0.000	0.000	<input type="checkbox"/>	0	0	0	<input type="checkbox"/>

The SINUMERIK 802D sl pro offers automatic tool monitoring.

- You can monitor tool wear by observing tool life and/or workpiece quantity. If a tool reaches its wear limit, an alarm is given automatically and the tool is suspended from further machining.
- You can specify the following data in tool monitoring:
 - Tool life, specified as a setpoint, and prewarning limit for tool monitoring. The time remaining before the tool is deactivated is calculated and displayed.
 - Workpiece quantity, specified as a setpoint, and prewarning limit for tool monitoring. The workpiece quantity remaining before the tool is deactivated is calculated and displayed.
 - Tool monitoring can be activated for tool life and/or quantity of workpieces.
- When tool life monitoring is activated, tool life is monitored during the tool's operation time (G1, G2, G3). Workpiece quantity is monitored using a program command at the end of the part program, usually Setpiece(1).

Highlight



- Efficient monitoring of tool life and workpiece quantity is standard

3.4 Face turning in MDA mode

Basic configuration

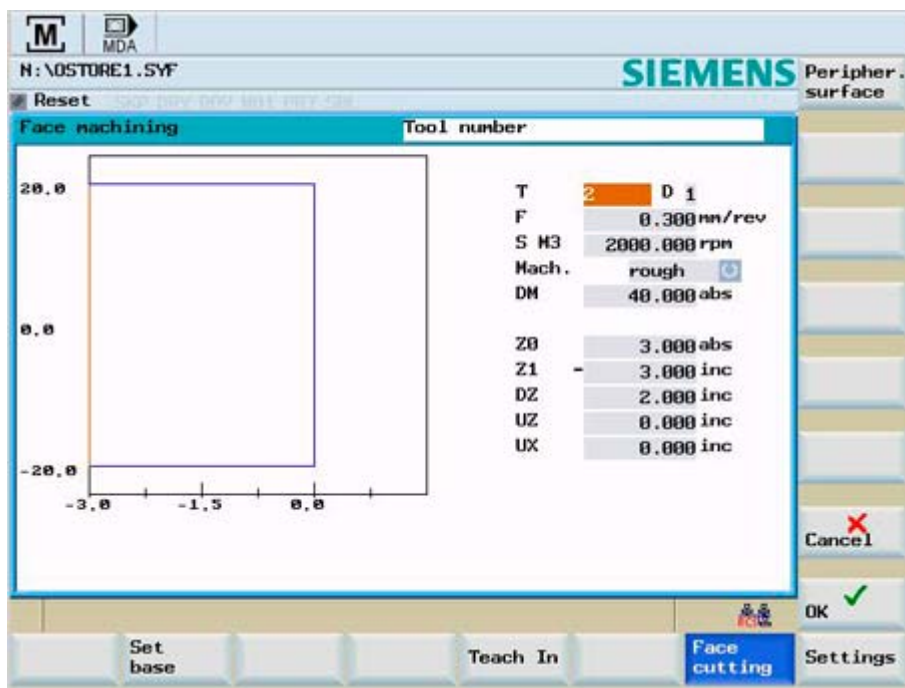

When preparing a blank workpiece, SINUMERIK 802D sl pro supports you in the following ways:

- Input of machining parameters by dialog, complete with tool, work offset, feedrate, and spindle speed
 - Position the axes on the starting point and enter the values in the mask
 - After entering the machining parameters press the OK button, the program will be created automatically; i.e. the programmer does not have to write the part programs himself.
- The MDI blocks are also retained after NC Start and can be saved as a part program.

Highlight



- Speedy preparation of the blank workpiece

Program management and user memory

4.1 Program Manager

Basic configuration

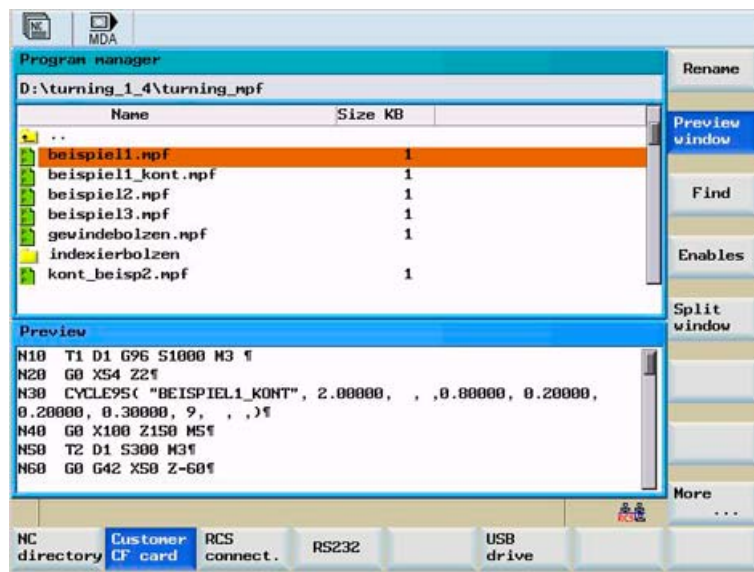

With the SINUMERIK 802D sl pro Program Manager, you can easily manage your part programs.

- PC-like functions, e.g. Mark, Copy, Paste, and Rename
- File names for part programs can be entered in clear text, making them easy to identify (max. 25 characters).
- Clear structures with subdirectories on several levels
- Quick search function based on entry of the 1st letter of the program name. The controller automatically positions the cursor on a program with the initial letter matching that which was entered.
- Preview of the first seven lines of the part program before editing
- All part programs available on the machine, thanks to the 3 MB user memory
- Access to shared network drives and sharing of directories for remote access via Ethernet networking

Highlights



- **Better overview with clear-text file names**
- **User-friendly data handling in typical PC style with copy, paste, rename, etc.**

4.2 User memory and data management

4.2.1 Buffered CNC user memory

Basic configuration

SINUMERIK 802D sl pro 3 MB

Management of up to 100 part programs. For larger quantities, we recommend that part programs be managed using the CF card.

Highlight



- Large memory space included in scope of delivery

4.2.2 Compact Flash card

Basic configuration, only CF card required

A Compact Flash card slot is located directly at the operator panel front of the SINUMERIK 802D sl.

- Card can be inserted or removed while power is on, i.e., the machine does not have to be restarted in order for the CF card to be recognized.
- Cover can be closed while the card is inserted in order to protect the unit from dust.
- Load and execute part programs from the CF card
- No loss in performance during execution of part programs from the CF card (DNC operation)
- No special software necessary for reading/writing CF cards at PC



Part programs on the CF card are not edited at the controller, but rather at the PC.

Highlight



- Efficient and reliable solution for handling a large volume of user data

4.2.3 Serial data transfer

- ☑ Basic configuration, installation of RCS802 tool on PC (included on Toolbox CD as standard)

The SINUMERIK 802D sl pro facilitates easy data transfer from and to the PC via the RS232 interface. To do this, install the RCS802 tool on your PC.

- Backing up of machine data
- Archive/series startup file
- Backing up of part program data



Note: If you have not received the Toolbox CD, please contact your machine OEM.

Highlight



- Easy data transfer with a proven track record

4.2.4 Ethernet networking

- ☑ SINUMERIK 802D sl pro

The SINUMERIK 802D sl pro is set up for Ethernet (TCP/IP) networking (RJ45 connection).

- The data transfer rate is 10/100 Mbps.
- Remote access to the controller via the RCS802 tool, e.g. for setup and remote diagnostics (PC license required)
- Access to the network drives is available directly from the program manager. No additional software is required on the server.

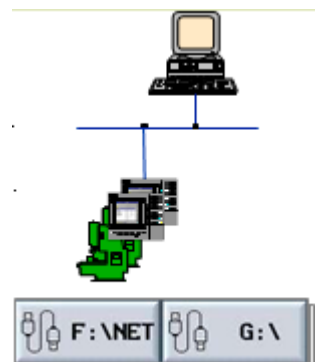

Highlight



- Easy and economical connection via Ethernet (TCP/IP) to Windows PCs or Unix workstations

Programming

5.1 DIN/ISO language

☑ Basic configuration

For DIN/ISO programming purposes, the SINUMERIK 802D sl pro offers a large pool of commands which are oriented to the task at hand:

- G-code according to DIN66025 and in ISO dialect mode (mixed programming possible with G290/G291 commands)
- G-functions and extended G-functions
Powerful commands, e.g. CIP for circular interpolation via intermediate point
- Unlimited number of programmable work offsets
Using the commands TRANS, SCALE, MIRROR, ROT, you can shift, scale, mirror, and rotate the workpiece coordinate system as required.
- Calculation operations and logic operations of variables
These calculation operations include, e.g.: +, -, *, /, sin, cos, exp, ==, <>
- User data
You can freely define variables in the part program using names (clear text) and type (LUDs, no GUDs).
- R parameters (calculation parameters)
300 predefined R parameters are available as flexible calculation variables (floating point format).
- System variables
Access from the program to, for example, tool offsets, axis positions and measuring values
- Program control structures
Language commands such as IF and GOTO are available for programming with conditions and loops.

Highlight



- **Unbeatable pool of commands for flexible and time-optimized part programs**

5.2 DIN/ISO editor

Basic configuration

For programming purposes, the SINUMERIK 802D sl pro has a text-based DIN/ISO editor. This allows you to directly enter or change CNC language commands, meaning that you have access to the entire range of CNC functions.

The editor offers the following range of functions:

- Easy-to-use program entry with Copy, Paste, Search/Replace, Numbering, etc.
- Graphics editor for creating workpiece contours entered in the program as G-code
- Standard machining cycles for turning, drilling, and milling
- Simulation of the program created
- Recompilation of program cycles for further editing in the graphical interface
- Direct execution from any NC program block (block search)

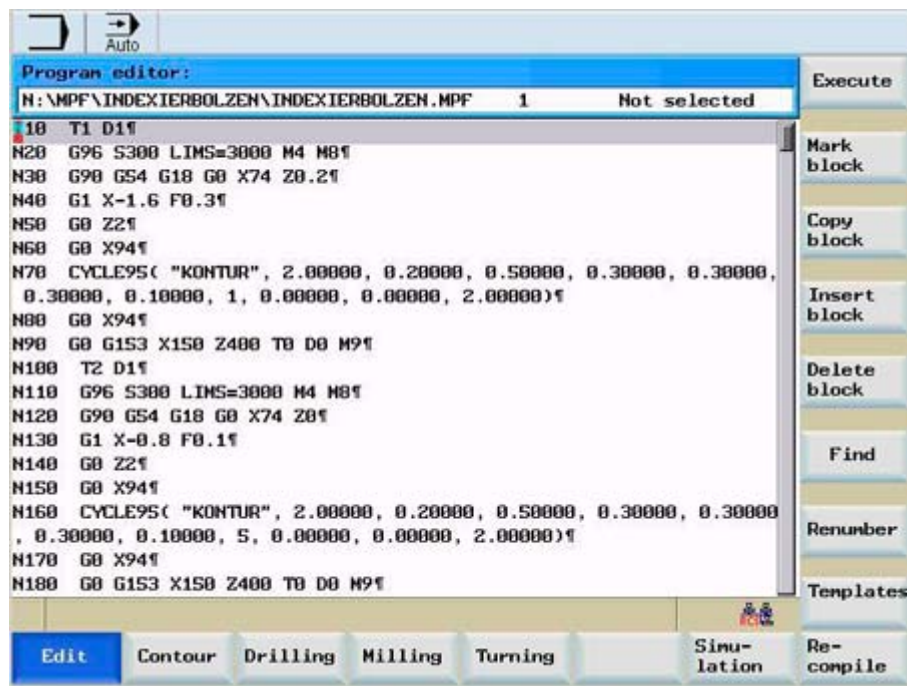

Highlight



- Save time by programming with efficient DIN/ISO editor

5.3 Machining Cycles

Basic configuration

For recurring machining operations, the SINUMERIK 802D sl pro provides you with graphical support for the following technology canned cycles. You can parameterize these and assemble them for the program in any way you wish.

- Turning
 - Face turning
 - Stock removal
 - Groove, undercut
 - Thread cutting, thread
- Drilling
 - Centering, drilling, counter-boring, reaming, deep-hole drilling, tapping
 - Repetition of hole machining using hole patterns row/circle (MCALL)
- Milling
 - Face milling
 - Contour milling
 - Rectangular pocket and spigot, circular pocket and spigot
 - Elongated holes on a circle, slots on a circle, circumferential slots
 - Thread milling (inside and outside)

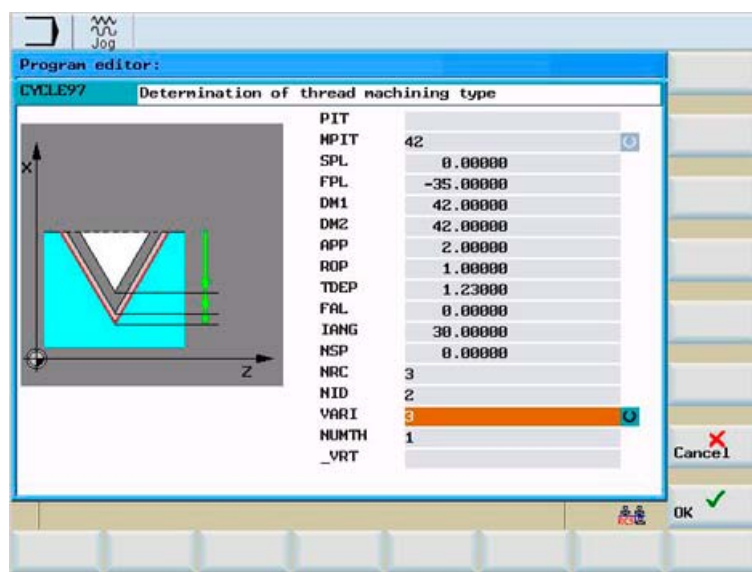

Comprehensive functional and graphical support is provided:

- For parameterization support is provided by the clear screens and infotexts accompanying the parameters, e.g. machining type of the thread.
- Tapping without compensating chuck is including in the basic scope, including thread interpolation (CYCLE84).
- You have extensive selection possibilities for high-performance machining, e.g. feed interruption for stock removal. The parameter DAM is used for this.

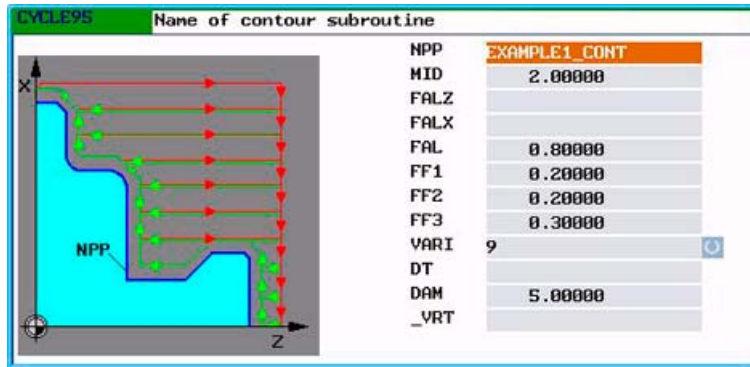

Highlight



- Graphical cycle support helps you create your part program faster
- Highly flexible G-code programming extended by graphical cycles

5.4 On-board user manual

Basic configuration

The on-board user manual provides descriptions of all important operator functions. In addition, it provides a complete description of NC commands, cycle programming and drive alarms (as can be found in the paper documentation).

You can call up the Help menu in the following ways:

- Pressing the Help key on the CNC keyboard to call up the table of contents
- Pressing the Help key to call up the context-sensitive help system, e.g. when the cursor is at a cycle parameter. Help is immediately opened at the relevant place.

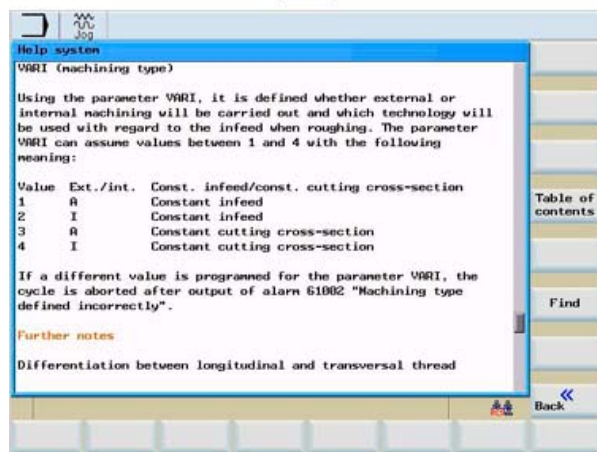
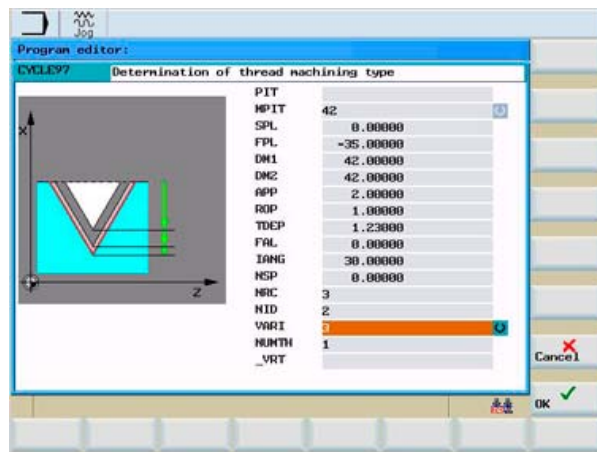

Highlight



- Never lose time again because you don't have the user manual at hand

5.5 On-board pocket calculator

Basic configuration

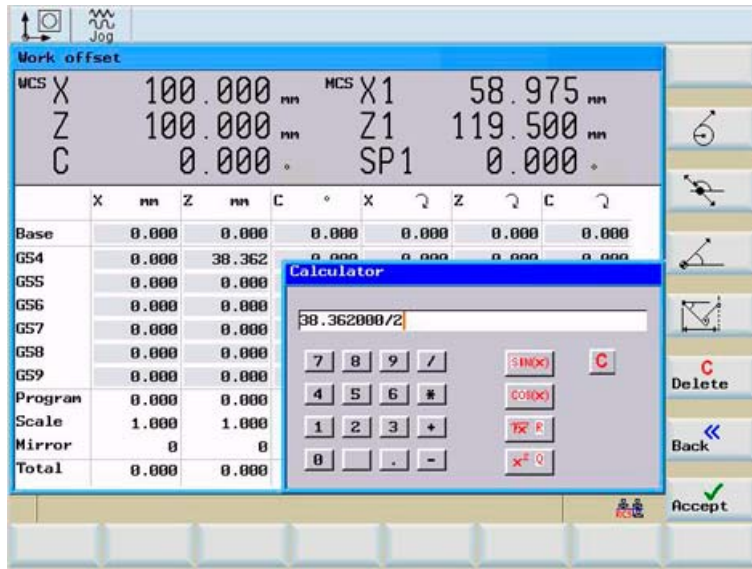

The on-board pocket calculator offers the following range of functions:

- Callable from any operating area
- Take over a value from an input field and write back to it after calculation
- Four basic calculation operations, as well as sine, cosine, square, and square root functions
- Bracket function for calculating nested terms
- Functions for calculating construction points on a contour, e.g.:
 - Tangential transition between a circle sector and a straight line
 - Converting polar coordinates to Cartesian coordinates
- By pressing the Input key, you can see the result of a calculation before you confirm it with the Accept softkey.

Highlight



- **More certainty for operating and programming thanks to on-board pocket calculator - no more calculation or typing mistakes**

5.6 Free Contour Programming / Contour Calculator

Basic configuration

The SINUMERIK 802D sl supports you in free programming of simple and complex contours. Free contour programming is a support tool for the DIN/ISO editor. Programs can be decompiled in the program editor and can thus be revised in the contour calculator.

You can include the following contour elements and parameterize them in screen forms:

- Straight line in the vertical direction (X direction)
- Straight line in the horizontal direction (Z direction).
- Oblique line in the X/Z direction. You can enter the end point of the straight line using coordinates or an angle.
- Arc with any direction of rotation.

Additional screen forms enable you to determine the starting point and to close the contour.

The contour calculator supports you in programming the following functions, among others:

- Calculation of only partly determined elements, as soon as the missing parameters can be derived from parameters already known, e.g. geometry data missing in the parts drawing.
- Chaining of contour elements.
- Insert radius or chamfer between two contour transition elements.
- Transfer of the programmed contours to the edited part program.
- Toggle between radius/diameter programming
- Undercuts as transition elements between two axis-parallel straight lines: Form E, form F, thread undercuts, free undercuts

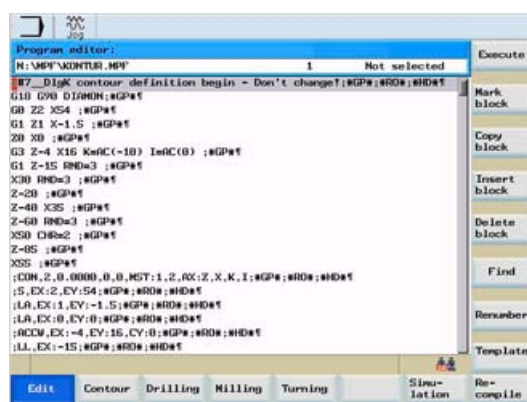
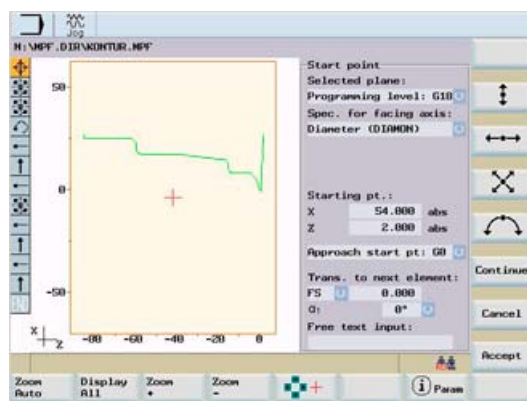

The following functions make work with the contour calculator easier:



When you select this softkey, you can use the cursor keys to determine a picture detail that is to be enlarged.

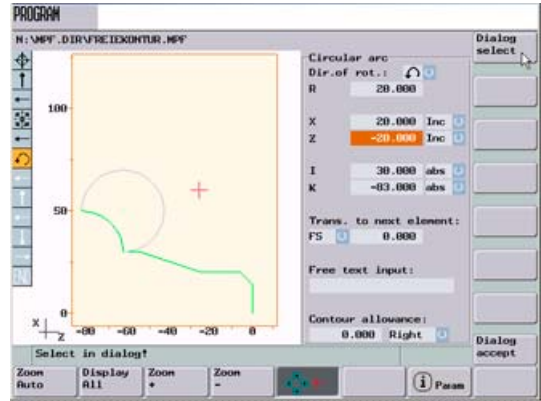

After selection of this softkey, graphical help screens will be displayed in addition to the relevant parameters.

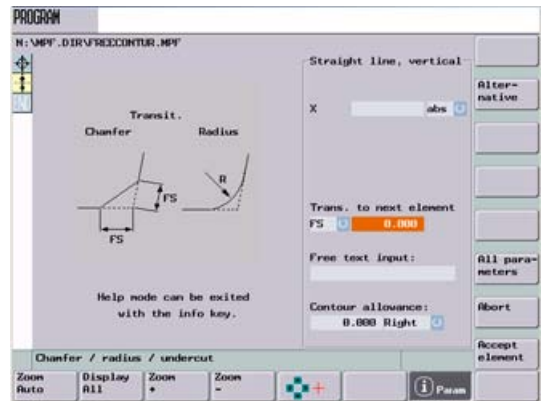

Highlight



- Speedy and certain from drawing to finished workpiece
- Program decompilation for further processing in the contour calculator
- Easy input of workpiece geometry: "Drawing dot to dot" like in ShopTurn

Simulation

Basic configuration

The SINUMERIK 802D sl pro offers you high process safety through integrated simulation, since it enables you to verify part programs before they are executed. By using broken-line graphics, you can trace the programmed tool path.

- Clear overview through use of different colors
Rapid feedrate = red
Cutting feedrate = blue
- Quickly display simulation result by activating dry-run feedrate (used instead of the programmed cutting feedrate)
- Possibility of zooming into details at any time during and after simulation
- Display the entire workpiece using the Zoom Auto softkey

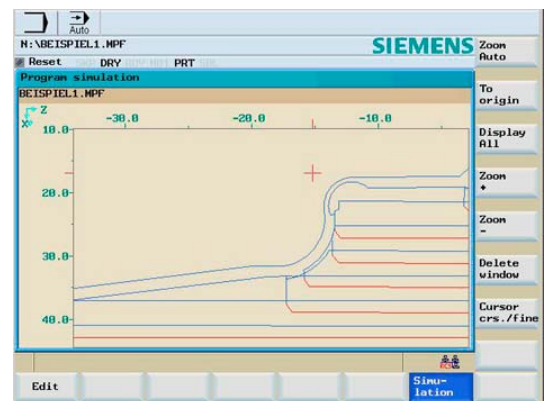
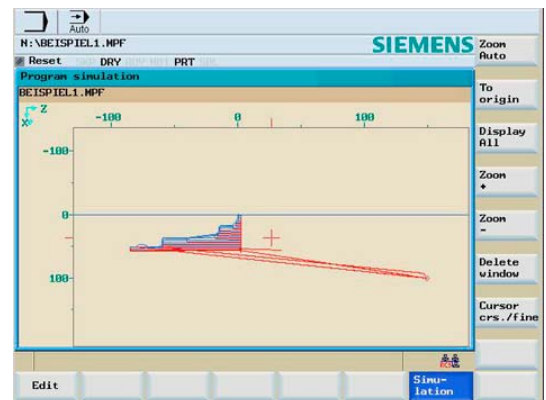

Highlight



- More process safety through effective simulation

Automatic mode

7.1 Program control

Basic configuration

Single block

Single block mode can be activated for startup of the program. There is a program stop after each traversing block.

Program test

Programs can be checked before processing in a program test mode. The program is executed to completion with stationary axes.

Program editing

In machine status STOP, the program can be edited directly at the location of the fault, e.g. erroneous DIN/ISO blocks. After correcting the program you can continue machining.

Repositioning to the contour

In machine status STOP, the machining axes can be moved to and away from the workpiece surface during machining using the handwheel or the direction keys.

Highlights



- Secure startup of new part programs
- Continue machining quickly after interruptions

7.2 Block search

Basic configuration

A block search may be executed in machine status RESET, e.g. after a program interruption or to specifically return to machining. The program data are prepared in such a way that all relevant parameters (tool, work offsets, etc.) are available upon continuation of the program.

The following search variants are available:

- To the interruption point
- To any CNC block in the DIN/ISO programs
- To any subroutine levels in DIN/ISO programs

Highlights



- Time-saving and secure re-start at any program point, as no editing of the part program is required

Velocity control

8.1 Jerk limitation

Basic configuration

The control calculates a steady acceleration profile instead of jumps in acceleration. This enables jerk-free velocity characteristics for the involved path axes. The jerk limitation can also be directly activated in the part program with the »SOFT« NC language command.

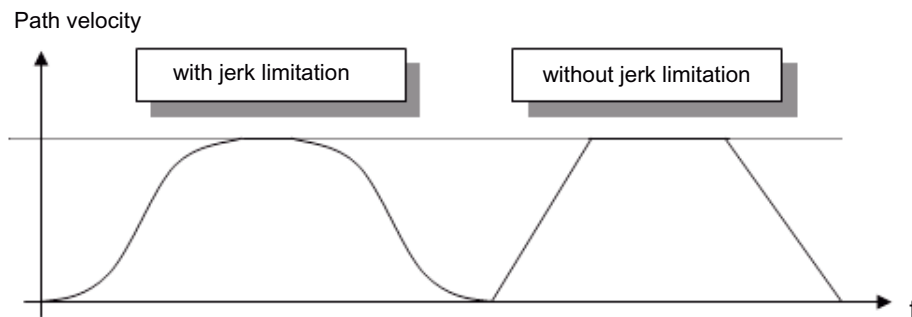

Highlights



- Longer machine lifespan through protection of the mechanical components
- Higher path accuracy through softer acceleration

8.2 Dynamic feedforward control

☑ Basic configuration

Inaccuracies in the resulting workpiece contour due to following errors can practically be eliminated using dynamic feedforward control FFWON. The result is excellent machining precision even at high tool path feedrates. This is clarified with a circularity test on the machine.

Example:

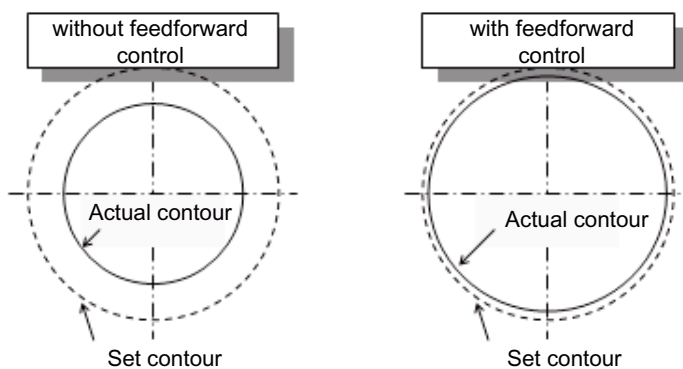

Highlight



- Higher path accuracy through compensation of contouring errors

C axis processing

9.1 Front surface machining

☑ Basic configuration

With the SINUMERIK 802D sl pro, hole machining and milling can be executed on the front face of workpieces in the main spindle.

The part program is easily created in a right-angle coordinate system with the front surface transformation TRANSMIT (C axis mode) .

The path movements are conducted with the linear axes X / Z and the rotary axis C.

Machine without Y axis

- Machining with TRANSMIT

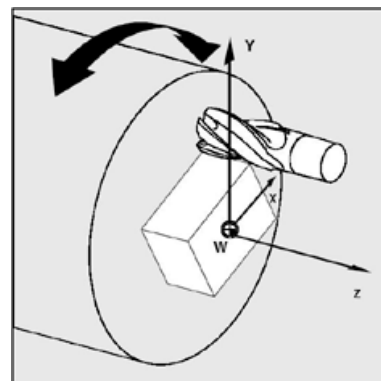

Highlights



- Full functional range for drilling and milling on the front end
- Reduction of set-up times by complete machining on one machine

9.2 Peripheral surface machining

☑ Basic configuration

With the 802D sl pro and the outer surface transformation TRACYL drilling and milling can be performed on the outer surface of workpieces in the main spindle.

- Any drill holes on the outer surface
- Any milling without slot wall offset on the outer surface
- Any milling with slot wall offset on the outer surface
- Grooving on parallel walls of the outer surface with milling radius correction

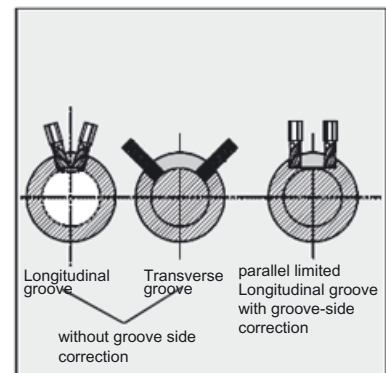
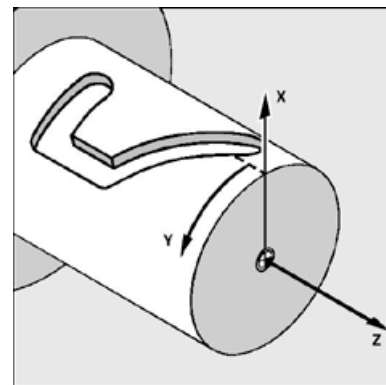

Highlights



- Full functional range for drilling and milling on the outer surface
- Reduction of set-up times by complete machining on one machine

Multilingual operator interface

Basic configuration

On the SINUMERIK 802D sl, the following languages are available on the operator interfaces. You can switch between these using a softkey.

- Chinese (simplified and traditional)
- German
- English
- Finnish
- French
- Italian
- Korean
- Dutch
- Polish
- Portuguese
- Romanian
- Russian
- Swedish
- Spanish
- Czech
- Turkish
- Hungarian



Highlight



- Operator interface in your language so that the CNC is easy to learn and safe to operate
- All languages are available on the control and can online be changed

Maintenance and diagnostics

11.1 Maintenance-free operation

Basic configuration

The SINUMERIK 802D sl offers maintenance-free operation:

- High reliability, because the SINUMERIK 802D sl has no hard disk, no battery and no fan
- Complete data backup on CF card, with all drive data

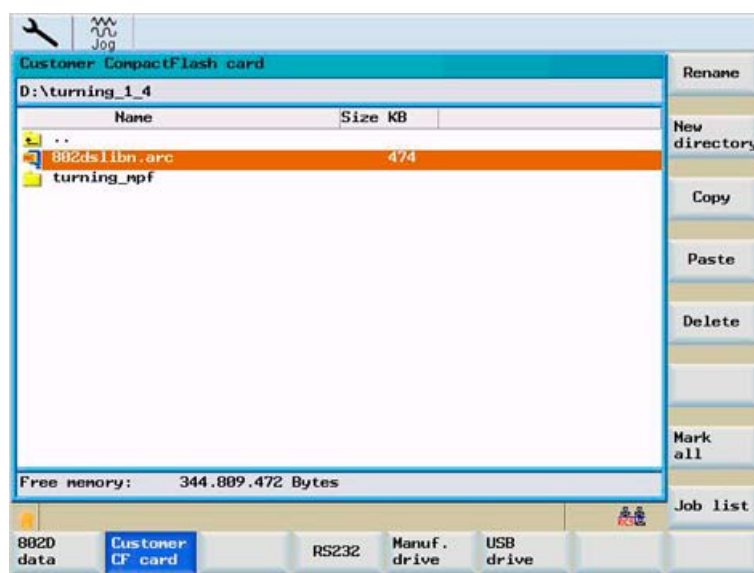

Highlight



- Highest machine availability thanks to reliable hardware
- Thanks to data backup via capacitor, regular battery changes are no longer required

11.2 Diagnostics

Basic configuration

The SINUMERIK 802D sl offers diagnostic functions which are easy to use:

- Diagnostic functions, such as ladder display, are available for finding causes of malfunctions or a PLC program error.
- You can switch between two windows in ladder display (e.g. for cross-references).
- You are provided with the same display as on a PC, with zoom, find, symbol info, and cross-reference functions.
- For reasons of safety, it is not possible to edit the PLC program at the machine.

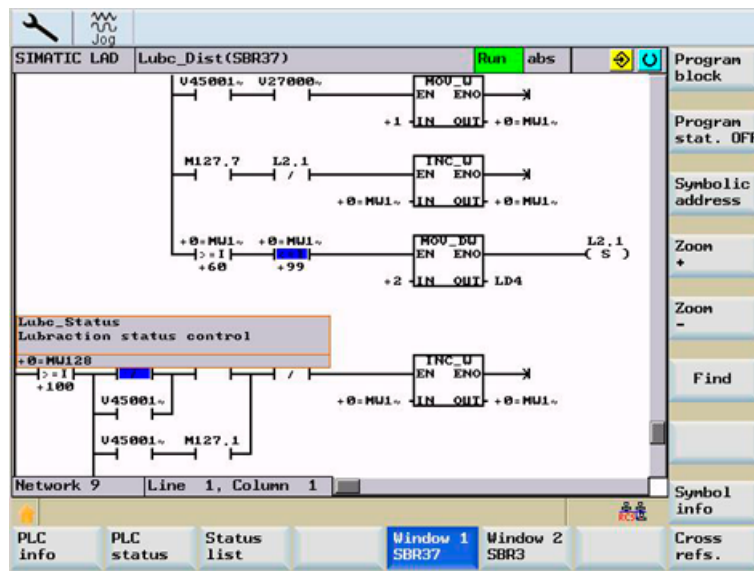

Highlight



- Highest machine availability thanks to modern diagnostic and troubleshooting tools

11.3 Remote diagnostics

- ☑ RCS802 on CD-ROM, included in scope of delivery
- ☑ Option: RCS802 remote diagnostics via Ethernet (PC license), only possible with SINUMERIK 802D sl pro

With the RCS802 software for PC, you can carry out remote diagnostics via the serial interface.

- With the SINUMERIK 802D sl pro, remote diagnostics can also be carried out via Ethernet (PC license).
- When connecting the PC to several machines, only one PC license is necessary for remote diagnostics via Ethernet.
- All machine tool controller diagnostic functions are also available in remote diagnostics.

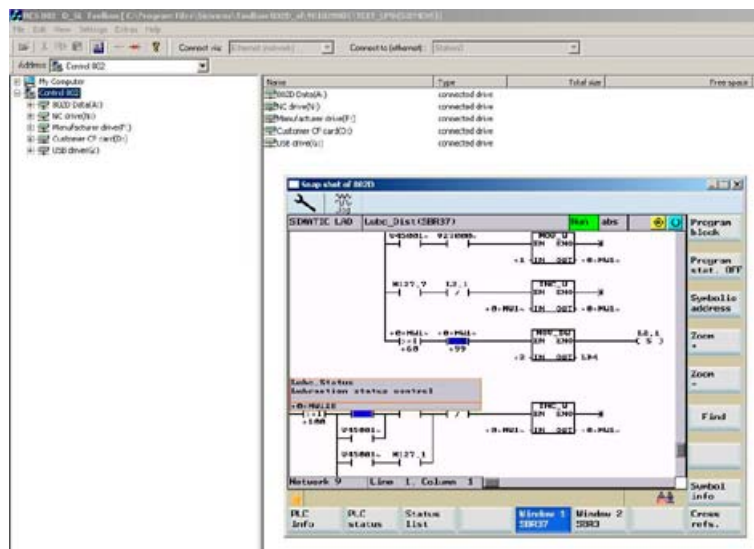

Highlight



- Shorter reaction times and lower service costs thanks to remote diagnostics

PC software

12.1 CAD reader for PC

Option: CAD reader for PC

You can convert contours and position patterns from PC-based DXF files into a format understandable to the controller with the PC software package "CAD Reader". You can continue editing contours in the DIN/ISO editor at the controller.

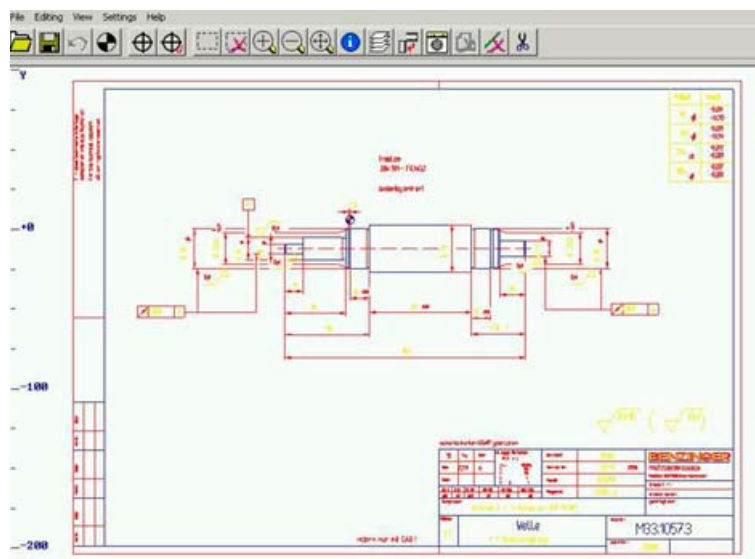

Highlight



- Save time by converting DXF files into contours and position patterns
- Work preparation and training at the PC without occupying the machine

12.2 SINUMERIK 802D on PC - SinuTrain

Option: SinuTrain 802D

Controller-identical PC system for work preparation and CNC training

- Complete range of functions of SINUMERIK 802D
- Networking of several student and trainer units possible



Highlight



- PC software for training and work preparation without occupying the machine

12.3 SINUMERIK 802D self-learning CD

Option: SINUMERIK 802D self-learning CD

Multimedia introduction to operation and programming with the SINUMERIK 802D

- Can be installed on PC
- Programming exercises with directed examples
- Available in three languages: German, English, and Chinese simplified



Highlight



- Graphically supported instruction software for beginners

Ordering data

Below is the information required for ordering:

SINUMERIK 802D sl pro	6FC5370-0AA00-3AA0
Toolbox CD-ROM -> Already included with each 802D sl: with additional language files for operator interface, RCS802 software, PLC programming tool, etc.	6FC5810-0YC00-0YA8
License disk for RCS802 remote diagnostics via Ethernet: (only possible with SINUMERIK 802D sl pro)	6FC6000-6DA51-0AA0

Additional functions of SINUMERIK 802D sl pro compared to SINUMERIK 802D sl plus:

- Connectivity via Ethernet
- USB stick pluggable on the rear of the PCU
- More CNC user memory: increased from 1 MB to 3 MB

Summary of unique selling points

The SINUMERIK 802D sl operator panel controller has the following selling points which make it stand out from the competition:

User-friendly operation

- Graphical support for setting up tools and workpiece zeros
- CF card for unlimited number of part programs
- Graphical program simulation with zoom

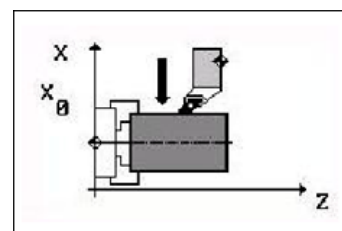

Time-saving programming

- Flexible G-code programming
- Graphical support for technological machining cycles, contour calculator as with ShopTurn
- Complete user manual on-board

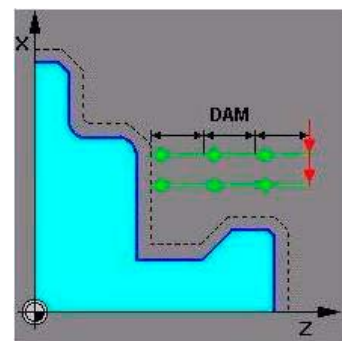

More productivity

- C axis machining with rotating tools
- Maintenance free and easy to diagnose
- Programming and training software on PC

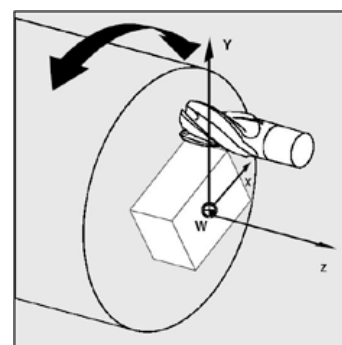

Index

8

802D on PC, 44

A

Application, 7

B

Block search, 32

C

CAD Reader, 43
CNC keyboard, 10
CNC memory, 18
Compact Flash card, 18
Contour calculator, 27
Contour programming, 27

D

DXF converter, 43

E

Ethernet, 19

F

Feedforward control, 34
Flash card, 18
Front end machining, 35

M

Machine spectrum, 7

N

Networking, 19

O

Operator panel front, 10
Ordering data, 45

P

PC software, 43
Peripheral surface machining, 36
Pocket calculator, 26
Program control, 31
Program editing, 31
Program manager, 17
Program test, 31

R

Repositioning to the contour, 31

S

Serial data transfer, 19
Single block, 31
SINUMERIK 802D sl, 9
SinuTrain, 44

T

TCP/IP, 19
Tool list, 14
TRACYL, 36
TRANSMIT, 35

U

Unique selling points, 47
USB stick, 45

User memory, 18

V

Velocity control, 33

W

Work offsets, 11